

DMT038WSHTCMI-1A

PRODUCT SPECIFICATION

Version 0.1
Aug 26, 2021

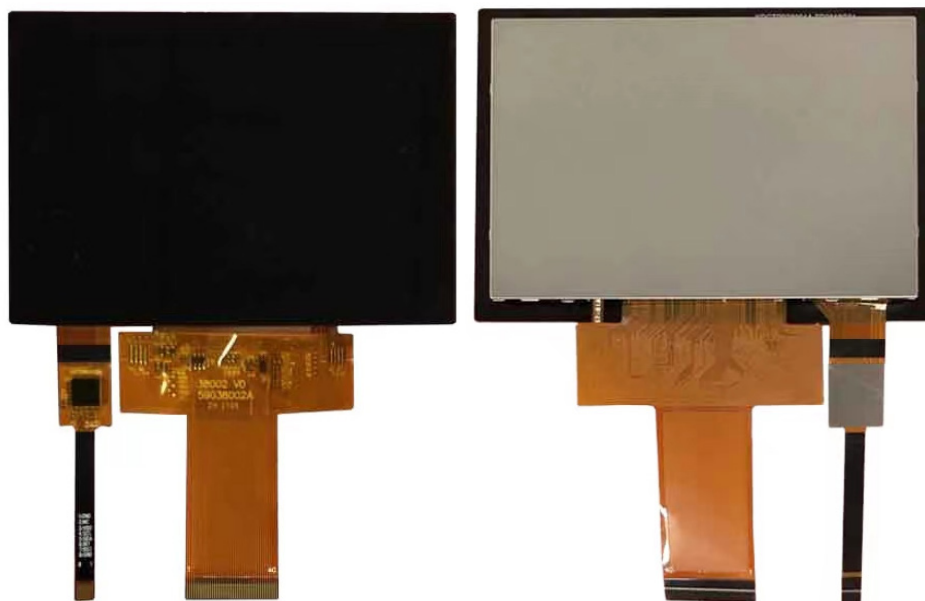

<i>Customer's Approval</i>	
<u>Signature</u>	<u>Date</u>

Prepared by *Chi Huang*
Approved by *Eric Wan*

Revision History

VERSION	DATE	DESCRIPTION	AUTHOR
0.1	Aug 26, 2021	Preliminary	Chi Huang

Legal Notice

Copyright ©2021 Quixant UK Limited trading as Densitron

All information contained in this document is proprietary and confidential to Quixant UK Limited trading as Densitron and is subject to a non-disclosure agreement. Unauthorized use, duplication, modification or disclosure of this information by any means without prior consent of Quixant UK Limited trading as Densitron is prohibited.

Every effort has been made to ensure the accuracy of this document; however, Quixant UK Limited trading as Densitron accepts no responsibility for any inaccuracies, errors or omissions herein. Quixant UK Limited trading as Densitron reserves the right to change specifications without prior notice in its absolute discretion, to supply the best product possible. Where Quixant UK Limited trading as Densitron or any of its group companies has (i) made a change to a product to incorporate a specific customer requirement or (ii) has created a design to a customer's specific requirements, in either case the customer will indemnify and hold the relevant Densitron entity harmless against any claim that delivery against such requirement breaches any intellectual property or other rights of any 3rd party.

All brands and trademarks are the property of their respective owners and are hereby fully acknowledged.

Table of Contents

1. GENERAL DESCRIPTION	5
1.1 Introduction	5
1.2 Main Features	5
1.3 Touch Features	6
2. MECHANICAL SPECIFICATION	7
2.1 Mechanical Characteristics	7
2.2 Mechanical Drawing	8
3. ELECTRICAL SPECIFICATION	9
3.1 Absolute Maximum Ratings	9
3.2 Electrical Characteristics	9
3.3 Interface Pin Assignment	10
3.4 Block Diagram	12
3.5 Timing Characteristics	13
4. ELECTRICAL SPECIFICATION TOUCH	16
4.1 Electrical Characteristics	16
5. OPTICAL SPECIFICATION	22
5.1 Optical Characteristics	22
6. LED BACKLIGHT SPECIFICATION	25
6.1 LED Backlight Characteristics	25
6.2 Internal Circuit Diagram	25
7. PACKAGING	26
8. QUALITY ASSURANCE SPECIFICATION	27
8.1 Conformity	27
8.2 Environment Required	27
8.3 Delivery Assurance	27
8.4 Dealing with Customer Complaints	35
9. RELIABILITY SPECIFICATION	36
9.1 Reliability Tests	36
10. HANDLING PRECAUTIONS	37

10.1	Handling Precautions	37
10.2	Storage Precautions	38
10.3	Designing Precautions.....	38
10.4	Operation Precautions	39
10.5	Other Precautions	39

CONFIDENTIAL

1. General Description

1.1 Introduction

This is a 3.8" size colour active matrix TFT LCD module that uses amorphous silicon TFT as a switching device. The display is normally black mode, transmissive, and featuring high contrast and excellent colour saturation. The resolution of the TFT-LCD is 1024 x 600 and can display up to 16.7M colours. The display module supports 16/18/24/ BIT RGB interface and optical bonding 5 points touch panel.

1.2 Main Features

Item	Contents
Display Type	TFT LCD
Screen Size	3.8" Diagonal
Display Format	1024 x RGB x 600 Dots
No. of Colour	16.7M
Overall Dimensions	97.92 (H) x 67.928 (V) x 4.81 (D) mm
Active Area	82.6368 (W) x 48.42 (H) mm
Mode	Normally Black / Transmissive
Surface Treatment	Glare (7H)
Viewing Direction	All round
Interface	16/18/24/ BIT RGB
Driver IC	JD9168
Backlight Type	LED, White, 14 chips
Touch Panel	PCT
Touch Interface	I ² C
Bonding Type	Optical Bonding
Operating Temperature	-20°C ~ +70°C
Storage Temperature	-30°C ~ +80°C
ROHS	Compliant to RoHS 2.0

1.3 Touch Features

Item	Contents
Touch Panel	PCT
Touch Interface	I ² C
Slave Address	0x5D(7bit) or 0x14(7bit)
Bonding Type	Optical Bonding
CTP Driver IC	GT911
Structure	G+G
Touch Mode	Five points

CONFIDENTIAL

2. Mechanical Specification

2.1 Mechanical Characteristics

Item	Characteristic	Unit
Display Format	1024 x RGB x 600 Dots	Dots
Overall Dimensions	97.92 (H) x 67.928 (V) x 4.81 (D)	mm
Active Area	82.6368 (W) x 48.42 (H)	mm
Dot Pitch	0.0807 (W) x 0.0807 (H)	mm
Weight	TBD	g
IC Controller/Driver	JD9168	

CONFIDENTIAL

2.2 Mechanical Drawing

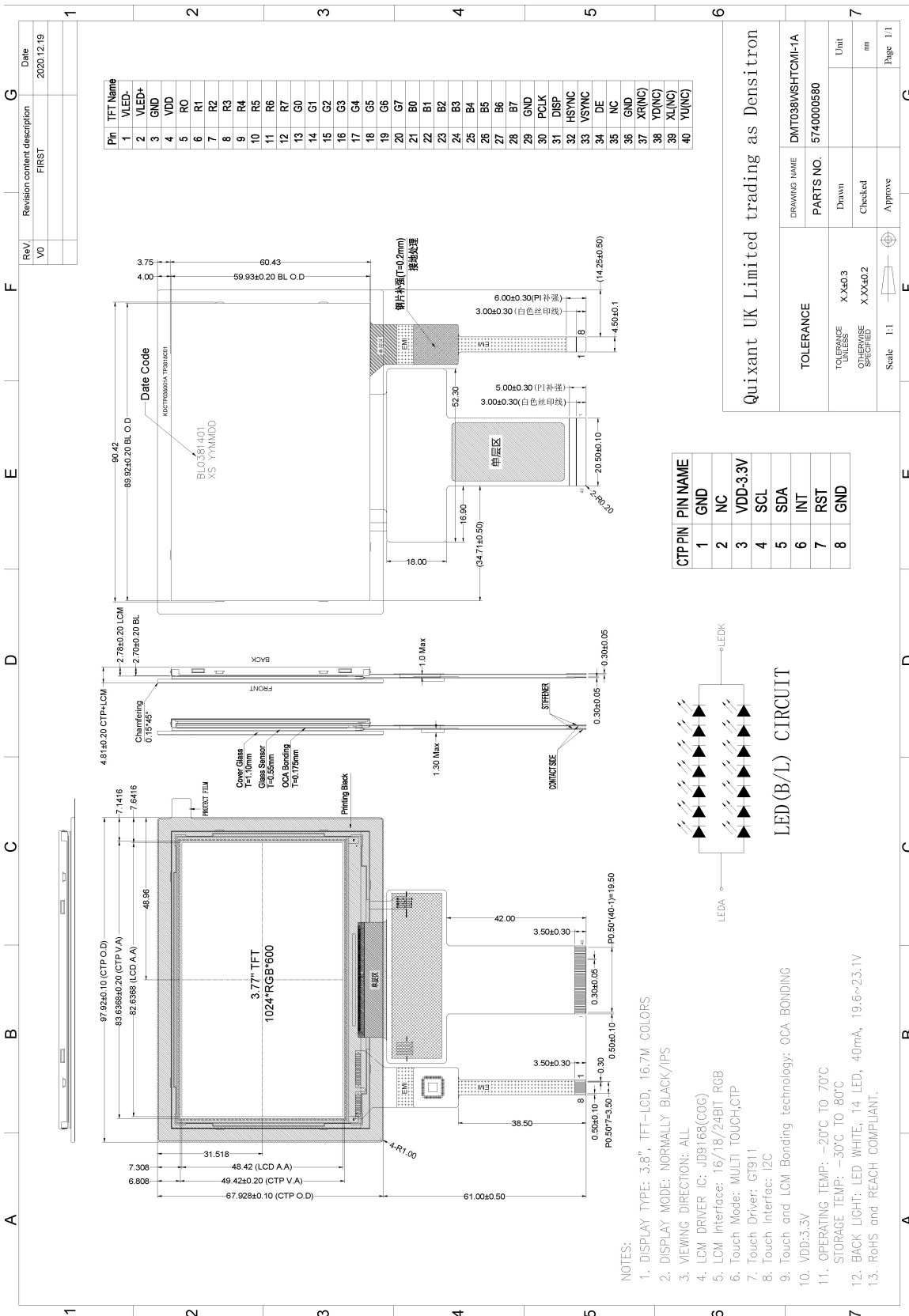

3. Electrical Specification

3.1 Absolute Maximum Ratings

Item	Symbol	Min	Max	Unit	Note
Digital Supply Voltage	VDD	-0.3	3.6	V	1
Operating Temperature	T _{OP}	-20	+70	°C	-
Storage Temperature	T _{ST}	-30	+80	°C	-

Note 1: When this module is used beyond the above absolute maximum ratings, permanent breakage of the module may occur. For normal operations, it is desirable to use this module under the conditions according to Section 3.2 “Electrical Characteristics”, to avoid malfunctioning.

Note 2: Background colour changes slightly depending on ambient temperature. This phenomenon is reversible.

Note 3: Please refer to item of RELIABILITY.

3.2 Electrical Characteristics

3.2.1 DC Characteristics

Characteristics	Symbol	Condition	Min.	Typ.	Max.	Unit	Note
Digital Supply Voltage	VDD	-	2.5	3.3	3.6	V	-
Normal mode Current consumption	I _{DD}	-	-	70	-	mA	-
Level input voltage	V _{IH}	-	0.7* VDD	-	VDD	V	-
	V _{IL}	-	0	-	0.3* VDD	V	-
Level output voltage	V _{OH}	-	0.8 VDD	-	VDD	V	-
	V _{OL}	-	0	-	0.2 VDD	V	-

3.3 Interface Pin Assignment

3.3.1 TFT Pin Define

NO.	Symbol	I/O	Function
1	LEDK	P	Cathode pin of backlight.
2	LEDA	P	Anode pin of backlight.
3	GND	P	Ground.
4	VDD	P	Supply voltage(3.3V).
5-12	R0-R7	I/O	8-bit digital Red data input.
13-20	G0-G7	I/O	8-bit digital Green data input.
21-28	B0-B7	I/O	8-bit digital Blue data input.
29	GND	P	Ground.
30	PCLK	I	Clock signal; latching data at the falling edge.
31	DISP	I	Display control / standby mode selection. DISP = "Low" : Standby. DISP = "High" : Normal display.
32	HSYNC	I	Horizontal sync signal; negative polarity
33	VSYNC	I	Vertical sync signal; negative polarity
34	DE	I	Data input enable. Active High to enable the data input When not used in SYNC mode, user should connect it to "Low" .
35	NC	-	-
36	GND	P	Ground.
37	XR(NC)	A/D	Touch panel Right Glass Terminal
38	YD(NC)	A/D	Touch panel Bottom Film Terminal
39	XL(NC)	A/D	Touch panel Left Glass Terminal
40	YU(NC)	A/D	Touch panel Top Film Terminal

3.3.2 CTP Pin Define

NO.	Symbol	I/O	Function
1	GND	P	Ground
2	NC	-	No Connection
3	VDD	P	Supply voltage
4	SCL	I	I ² C clock input
5	SDA	I	I ² C data input and output
6	INT	I	External interrupt to the host
7	RST	I	External Reset, Low is active
8	GND	P	Ground

CONFIDENTIAL

3.4 Block Diagram

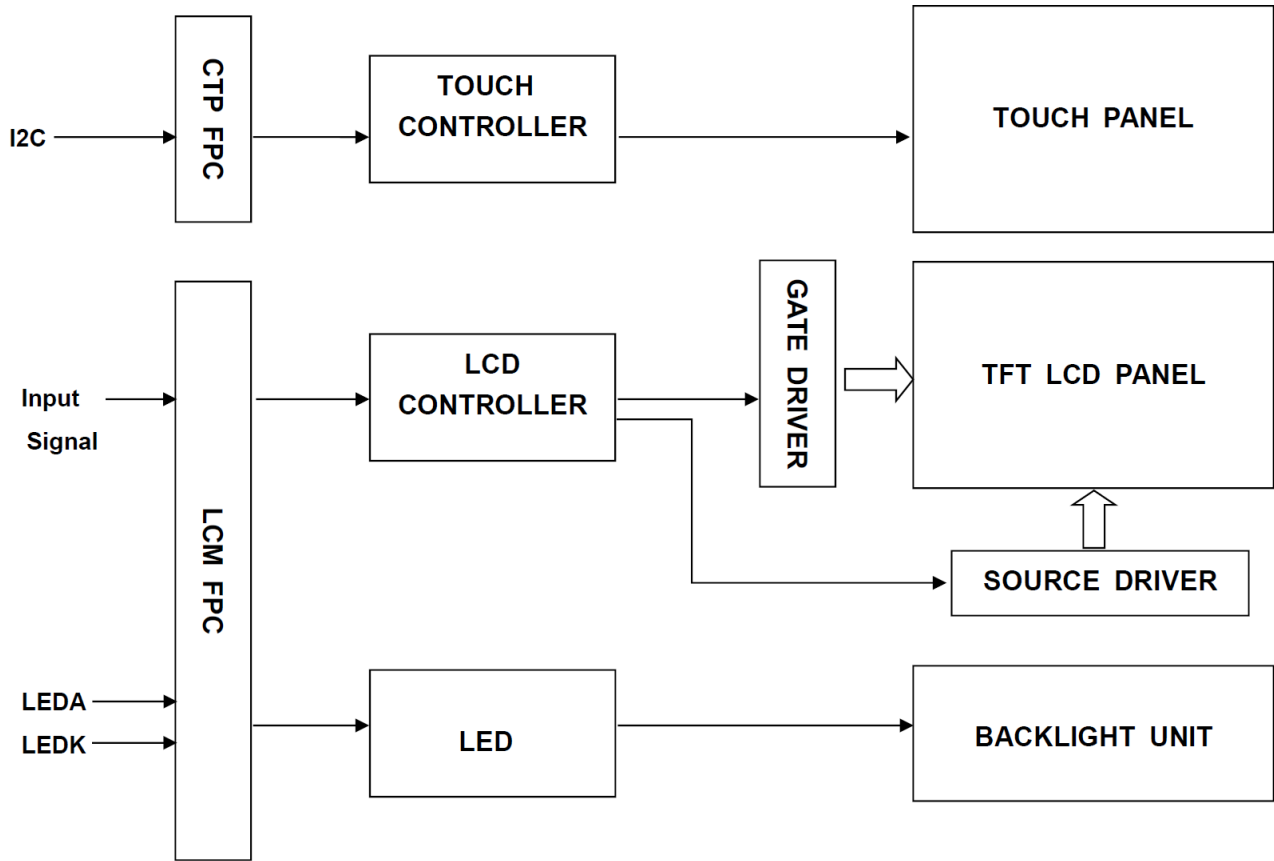

CONFIDENTIAL

3.5 Timing Characteristics

3.5.1 RGB Data format

The JD9168 supports 16-bit, 18-bit or 24-bit parallel RGB interface which includes: HSYNC, VSYNC, DE, PCLK, DB[23:0]. The interface is active after Power On sequence. Pixel clock (PCLK) is running all the time without stopping and it is used to entering HS, VS, DE and D[23:0] lines states when there is a rising edge of the PCLK. The PCLK cannot be used as continue internal clock for other functions of the display module e.g. Sleep In– mode etc. Vertical synchronization (VSYNC) is start signal to receive a “new frame” of the display. This is negative (“-”, “0”, low) active by rising edge of the PCLK-line. Horizontal synchronization (HSYNC) is start signal to receive a “new line” of the frame. This is negative (“-”, “0”, low) active by rising edge of the PCLK- line. Data enable (DE) is used to receive RGB information that should be transferred on the display. This is positive (“+”, “1”, high) active by rising edge of the PCLK-line.

The pixel clock cycle is described in the following figure.

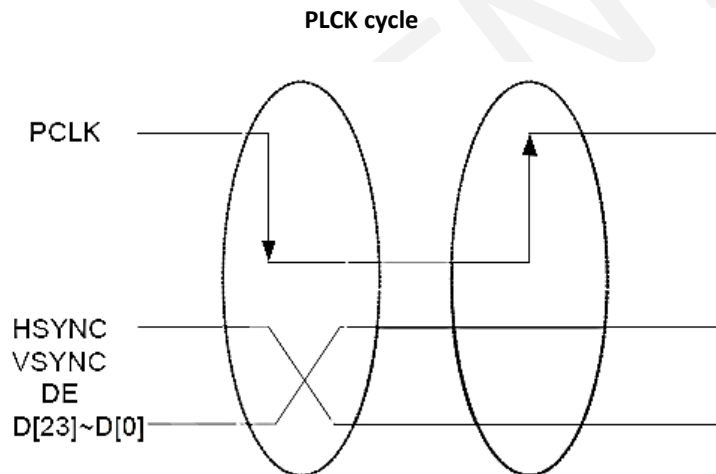

Note: PCLK is an unsynchronized signal (it can stopped).

RGB Interface data format

Data format	D23	D22	D21	D20	D19	D18	D17	D16	D15	D14	D13	D12	D11	D10	D9	D8	D7	D6	D5	D4	D3	D2	D1	D0
16 bit (3Ah=0x50)	R4	R3	R2	R1	R0				G5	G4	G3	G2	G1	G0			B4	B3	B2	B1	B0			
18 bit (3Ah=0x60)	R5	R4	R3	R2	R1	R0			G5	G4	G3	G2	G1	G0			B5	B4	B3	B2	B1	B0		
24 bit (3Ah=0x70)	R7	R6	R5	R4	R3	R2	R1	R0	G7	G6	G5	G4	G3	G2	G1	G0	B7	B6	B5	B4	B3	B2	B1	B0

3.5.2 General timing diagram

The image information can be incorrect on the display, when timings are out of the range on the interface (Out of the range timings cannot cause any damage on the display module or it cannot cause any damage on the host side). If it is returned from out of the range to in range timings, then the correct display image must be displayed automatically (by the display module) on the next frame (vertical sync.).

General timing diagram

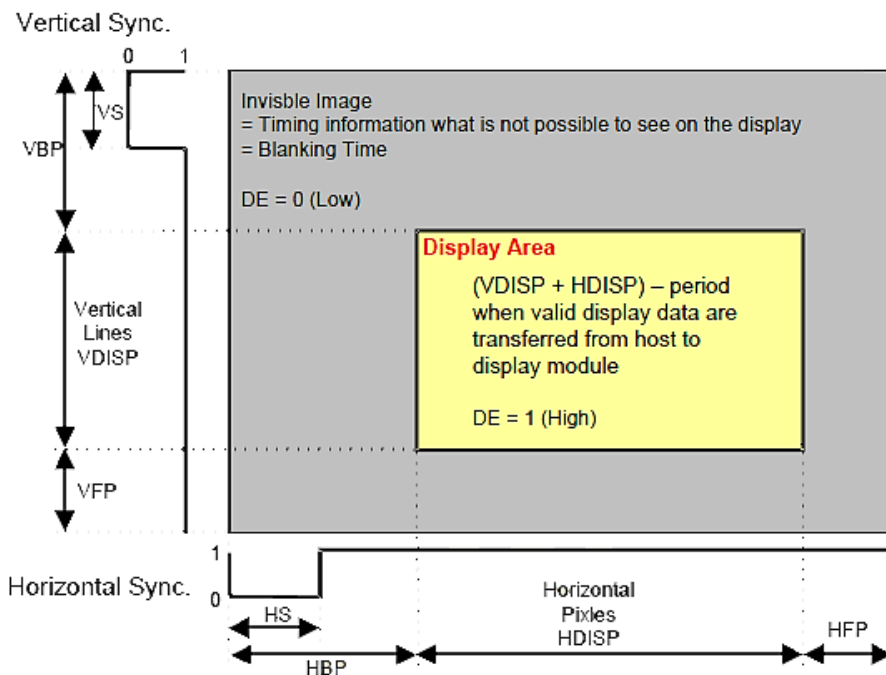

RGB (800RGBx480) timing diagram

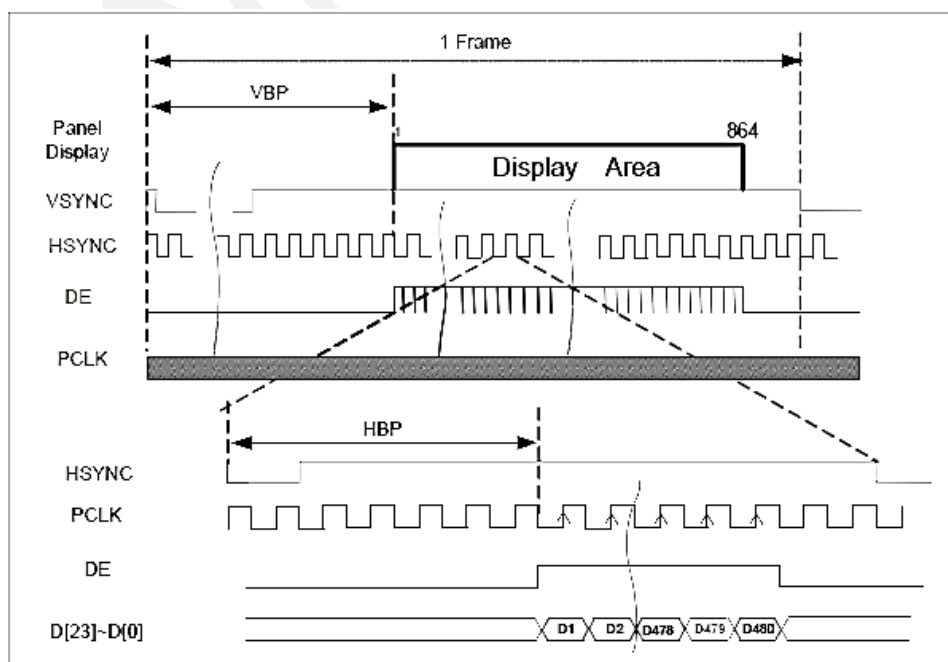

3.5.3 Timings for RGB mode

Parameter	Symbol	Min.	Typ.	Max.	Unit
DCLK frequency	FCLK	-	(51)	-	MHz
Horizontal display area	HDISP	-	1024	-	Clock
Horizontal Sync. Width	hpw	1	8	-	Clock
Horizontal Sync. Back Porch	hbp	1	210	-	Clock
Horizontal Sync. Front Porch	hfp	1	80	-	Clock
Vertical display area	VDISP	--	600	-	Line
Vertical Sync. Width	vs	2	8	-	Line
Vertical Sync. Back Porch	vbp	2	23	-	Line
Vertical Sync. Front Porch	vfp	2	12	-	Line
Frame-Rate	-	-	60	-	Hz

CONFIDENTIAL

4. Electrical Specification Touch

4.1 Electrical Characteristics

4.1.1 Absolute Maximum Ratings

Item	Symbol	Min.	Max.	Unit	Note
Power Supply Voltage	VDD	2.66	3.47	V	1
Operating Temperature	T _{OP}	-30	+85	°C	-
Storage Temperature	T _{ST}	-30	+85	°C	-

Note 1: If used beyond the absolute maximum ratings, permanent breakage of the module may occur. It is strongly recommended that the device be used within the electrical characteristics in normal operations. If exposed to the condition not within the electrical characteristics, it may affect the reliability of the device.

4.1.2 DC Electrical Characteristics

(Ambient temperature:25°C, AVDD=2.8V, VDDIO=1.8V or VDDIO=AVDD)

Item	Symbol	Condition	Min	Typ.	Max	Unit	Note
Power Supply Voltage	VDD	-	2.66	3.3	3.47	V	-
Normal Mode Operating Current	-	-	-	8	14.5	mA	-
Green Mode Operating Current	-	-	-	3.3	-	mA	-
Sleep Mode Operating Current	-	-	70	-	120	uA	-
Doze Mode Operating Current	-	-	-	0.78	-	mA	-
Digital Input Low Voltage	V _{IL}	-	-0.3	-	0.25xVDD	V	-
Digital Input High Voltage	V _{IH}	-	0.75xVDD	-	VDDIO+0.3	V	-
Digital Output Low Voltage	V _{OL}	-	-	-	0.15xVDD	V	-
Digital Output High Voltage	V _{OH}	-	0.85xVDD	-	-	V	-

4.1.3 AC Characteristics

(Ambient temperature:25°C, AVDD=2.8V, VDDIO=1.8V)

Item	Symbol	Condition	Min	Typ.	Max	Unit	Note
OSC oscillation frequency	-	-	59	60	61	MHz	-
I/O output rise time, low to high	-	-	-	14	-	ns	-
I/O output fall time, high to low	-	-	-	14	-	ns	-

4.1.4 I²C Timing

GT911 provides a standard I2C interface for SCL and SDA to communicate with the host. GT911 always serves as slave device in the system with all communication being initialized by the host. It is strongly recommended that transmission rate be kept at or below 400Kbps. The I2C timing is shown below:

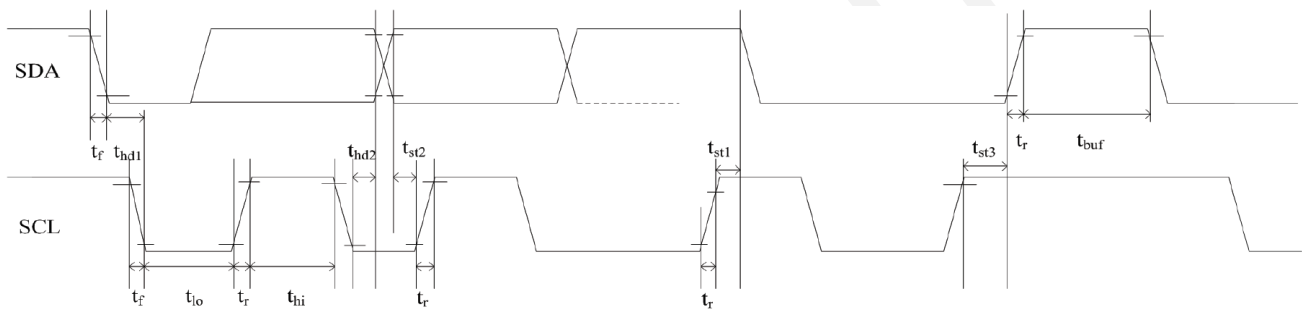

Test Condition 1: 1.8V host interface voltage, 400Kbps transmission rate, 2K pull-up resistor.

Item	Symbol	Min	Max	Unit	Note
SCL low period	t_{io}	1.3	-	us	-
SCL high period	t_{hi}	0.6	-	us	-
SCL setup time for Start condition	t_{st1}	0.6	-	us	-
SCL setup time for Stop condition	t_{st3}	0.6	-	us	-
SCL hold time for Start condition	t_{hd1}	0.6	-	us	-
SDA setup time	t_{st2}	0.1	-	us	-
SDA hold time	t_{hd2}	0	-	us	-

Test Condition 2: 3.3V host interface voltage, 400Kbps transmission rate, 2K pull-up resistor.

Item	Symbol	Min	Max	Unit	Note
SCL low period	t_{lo}	1.3	-	us	-
SCL high period	t_{hi}	0.6	-	us	-
SCL setup time for Start condition	t_{st1}	0.6	-	us	-
SCL setup time for Stop condition	t_{st3}	0.6	-	us	-
SCL hold time for Start condition	t_{hd1}	0.6	-	us	-
SDA srtup time	t_{st2}	0.1	-	us	-
SDA hold time	t_{hd2}	0	-	us	-

GT911 supports two I2C slave addresses: 0xBA/0xBB and 0x28/0x29. The host can select the address by changing the status of Reset and INT pins during the power-on initialization phase. See the diagram below for configuration methods and timings:

Power-on Timing:

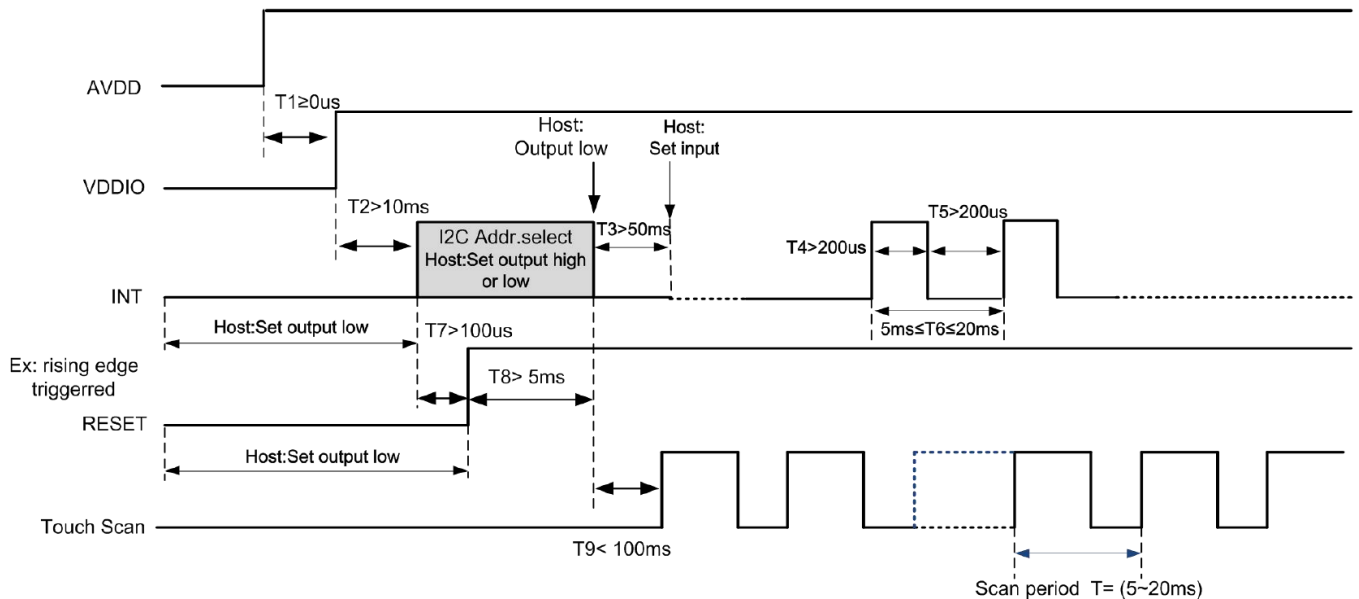

Timing for host resetting GT911:

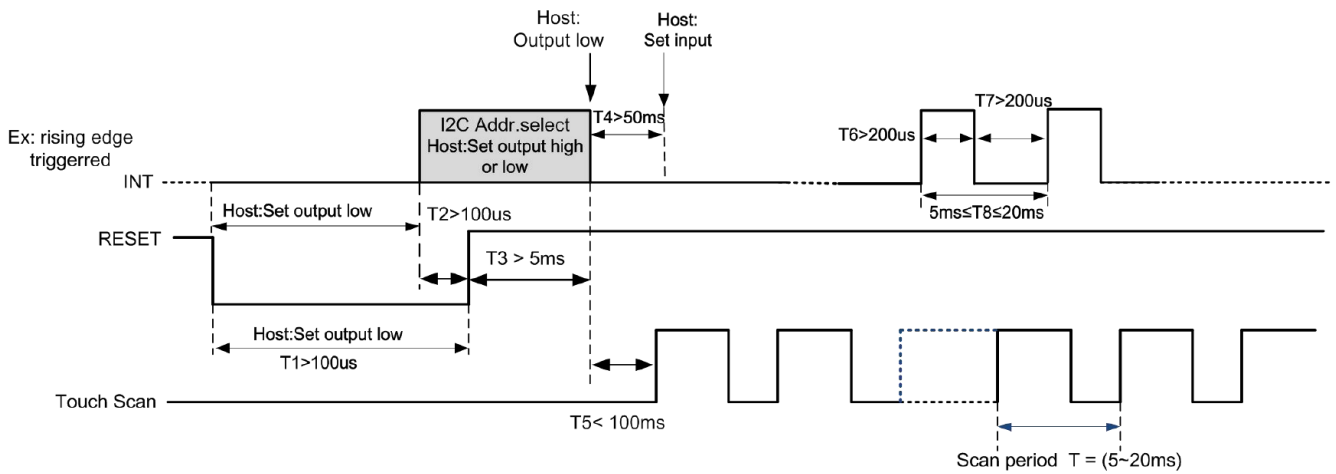

Timing for setting slave address to 0x28/0x29:

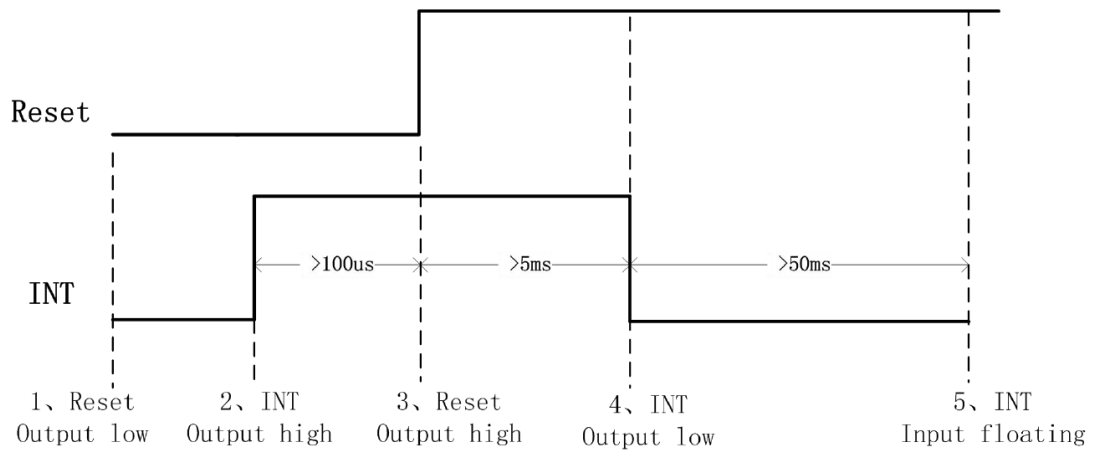

Timing for setting slave address to 0xBA/0xBB:

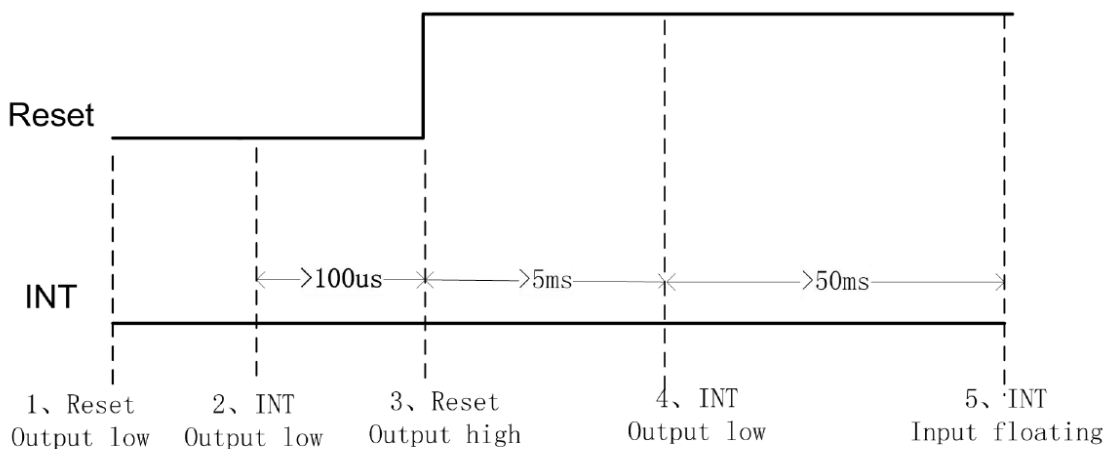

a) Data Transmission

(For example : device address is 0xBA/0xBB)

Communication is always initiated by the host. Valid Start condition is signaled by pulling SDA line from “high” to “low” when SCL line is “high”. Data flow or address is transmitted after the Start condition.

All slave devices connected to I2C bus should detect the 8-bit address issued after Start condition and send the correct ACK. After receiving matching address, GT911 acknowledges by configuring SDA line as output port and pulling SDA line low during the ninth SCL cycle. When receiving unmatched address, namely, not 0xBA or 0xBB, GT911 will stay in an idle state.

For data bytes on SDA, each of 9 serial bits will be sent on nine SCL cycles. Each data byte consists of 8 valid data bits and one ACK or NACK bit sent by the recipient. The data transmission is valid when SCL line is “high”.

When communication is completed, the host will issue the STOP condition. Stop condition implies the transition of SDA line from “low” to “high” when SCL line is “high”.

b) Writing Data to GT911

(For example: slave address is 0xBA/0xBB)

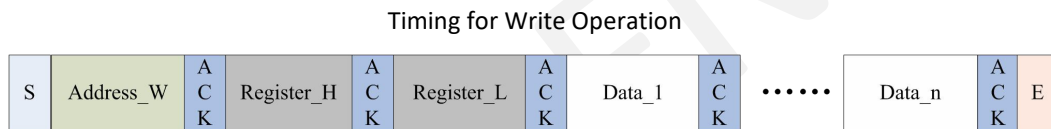

The diagram above displays the timing sequence of the host writing data onto GT911. First, the host issues a Start condition. Then, the host sends 0xBA (address bits and R/W bit; R/W bit as 0 indicates Write operation) to the slave device.

After receiving ACK, the host sends the 16-bit register address (where writing starts) and the 8-bit data bytes (to be written onto the register).

The location of the register address pointer will automatically add 1 after every Write Operation. Therefore, when the host needs to perform Write Operations on a group of registers of continuous addresses, it is able to write continuously. The Write Operation is terminated when the host issues the Stop condition.

c) Reading Data from GT911

(For example: slave address is 0xBA/0xBB)

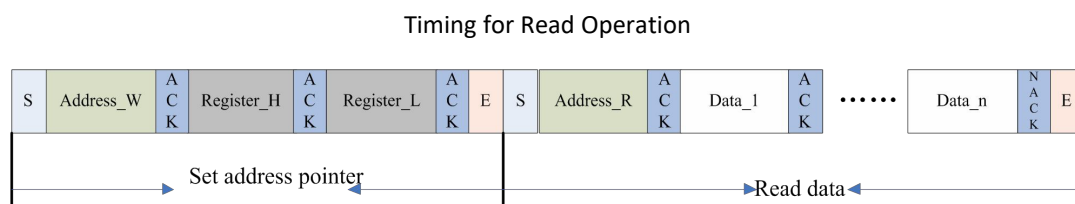

The diagram above is the timing sequence of the host reading data from GT911. First, the host issues a Start condition and sends 0XBA (address bits and R/W bit; R/W bit as 0 indicates Write operation) to the slave device.

After receiving ACK, the host sends the 16-bit register address (where reading starts) to the slave device. Then the host sets register addresses which need to be read.

Also after receiving ACK, the host issues the Start condition once again and sends 0XBB (Read Operation). After receiving ACK, the host starts to read data.

GT911 also supports continuous Read Operation and, by default, reads data continuously. Whenever receiving a byte of data, the host sends an ACK signal indicating successful reception. After receiving the last byte of data, the host sends a NACK signal followed by a STOP condition which terminates communication.

CONFIDENTIAL

5. Optical Specification

5.1 Optical Characteristics

Characteristics		Symbol	Conditions	Min	Typ.	Max	Unit	Note
Contrast Ratio		CR	$\theta = 0^\circ$	800	1000	-	-	1, 2
Response time		T_{R+T_F}	Normal	-	35	45	msec	1, 3
Color Gamut		S(%)	viewing angle	37	42	-	%	-
Viewing Angle	Left	θ_{x-}	CR > 10	75	85	-	deg	1, 4
	Right	θ_{x+}		75	85	-		
	Up	θ_{y+}		75	85	-		
	Down	θ_{y-}		75	85	-		
Colour Chromaticity	Red	Rx	$\theta = 0^\circ$ Normal viewing angle	-0.04	0.5797	+0.04	-	1, 4 CA-310
		Ry			0.3360			
	Green	Gx			0.3570			
		Gy			0.5381			
	Blue	Bx			0.1597			
		By			0.1480			
	White	Wx			0.3035			
		Wy			0.3400			
Luminance		Lv	$I_F = 40 \text{ mA}$	710	810	-	cd/m ²	5
Uniformity		Avg	-	80	-	-	%	5

Measuring Condition: in dark room, at ambient temperature = 25±2°C, 15 min. warm-up time

Note	Item	Test method
1	Definition of Viewing Angle	

Note	Item	Test method
2	Definition of Contrast Ratio (CR)	Measured at the center point of panel $\text{Contrast ratio (CR)} = \frac{\text{Luminance measured when LCD is at "white state"}}{\text{Luminance measured when LCD is at "black state"}}$
3	Definition of Response Time	<p>Display data: Black (TFT OFF) → White (TFT ON) → Black (TFT OFF)</p> <p>Optical Response: 100%, 90%, 10%, 0%</p> <p>Response time markers: Tr (rise time), Tf (fall time)</p>
4	Definition of Optical Measurement Setup	<p>Photo-detector (BM-5A)</p> <p>50cm</p> <p>Field=1°</p> <p>Center of panel</p> <p>LCD panel</p>
5	Definition of Luminance Uniformity	Luminance Uniformity of these 9 points is defined as below:

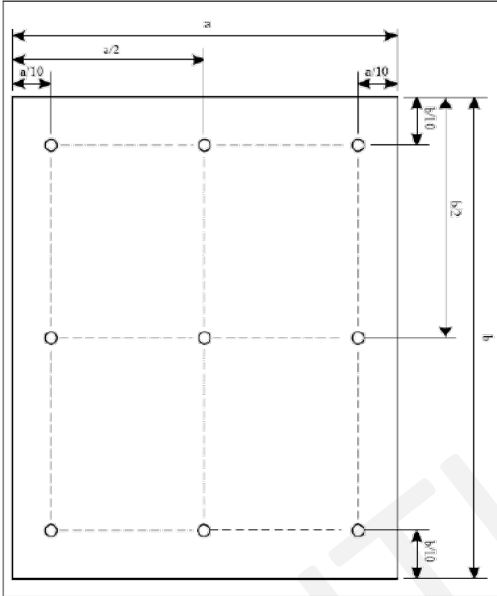
Note	Item	Test method
		 <p data-bbox="689 958 1300 1030"> $\text{Uniformity} = \frac{\text{minimum luminance in 9 points (1-9)}}{\text{maximum luminance in 9 points (1-9)}}$ </p> <p data-bbox="762 1048 1173 1102"> $\text{Luminance} = \frac{\text{Total Luminance of 9 points}}{9}$ </p>

CONFIDENTIAL

6. LED Backlight Specification

6.1 LED Backlight Characteristics

The backlight system is edge-lighting type with 14 chips LED.

Item	Symbol	Condition	Min	Typ.	Max	Unit	Note
Forward Current	I_F	-	30	40	-	mA	-
Forward Voltage	V_F	-	19.6	21.35	23.1	V	-
LED Life Time	Hr	-	-	50000	-	Hour	1, 2

Note 1: LED Life Time (Hr) can be defined as the time in which it continues to operate under the condition:

$T_a=25\pm 3^\circ\text{C}$, typical IL (I_F) value indicated in the above table until the brightness becomes less than 50%.

Note 2: The "LED Life Time" is defined as the module brightness decreases to 50% original brightness at $T_a=25^\circ\text{C}$ and $I_L=40\text{mA}$. The LED lifetime could be decreased if operating I_L is larger than 40mA. The constant current driving method is suggested.

6.2 Internal Circuit Diagram

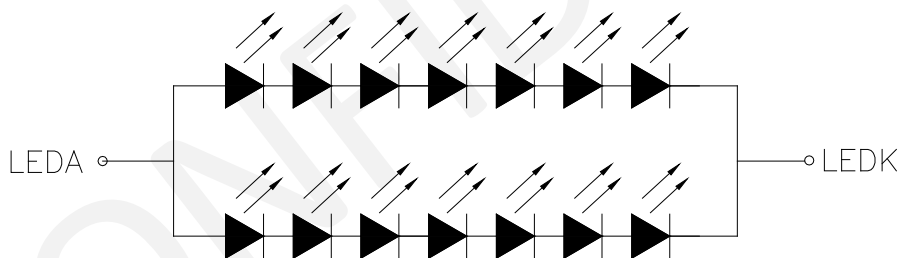

LED (B/L) CIRCUIT

7. Packaging

TBD

CONFIDENTIAL

8. Quality Assurance Specification

8.1 Conformity

The performance, function and reliability of the shipped products conform to the Product Specification.

8.2 Environment Required

Customer's test & measurement are required to be conducted under the following conditions:

Temperature:	25 ± 5°C
Humidity:	65% ± 10% RH
Viewing Angle:	Normal Viewing Angle
Illumination:	Single fluorescent lamp (300 to 700 Lux)
Viewing distance:	30 - 50cm

Finger glove (or finger cover) must be worn by the inspector.

Inspection table or jig must be anti-electrostatic.

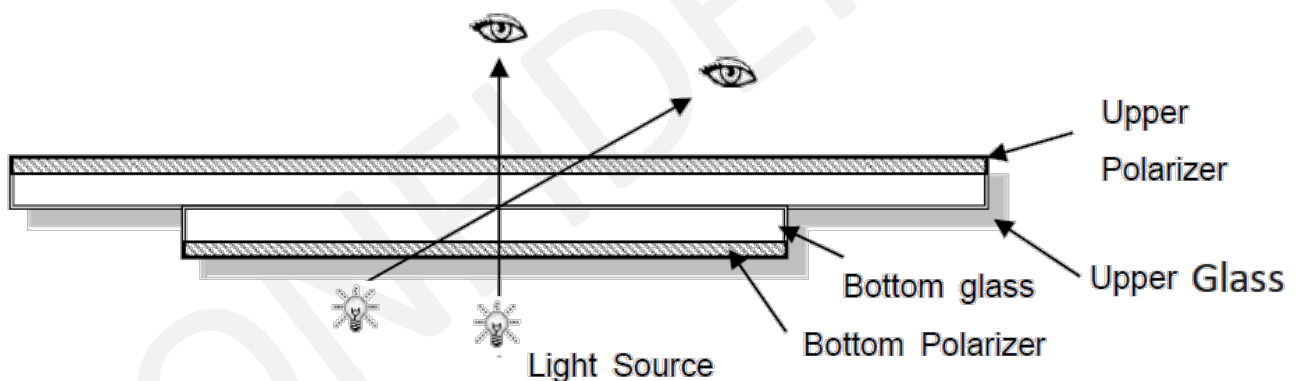

8.3 Delivery Assurance

8.3.1 Delivery Inspection Standards

Class II, Normal Inspection, GB/T 2828-2003

8.3.2 Zone Definition

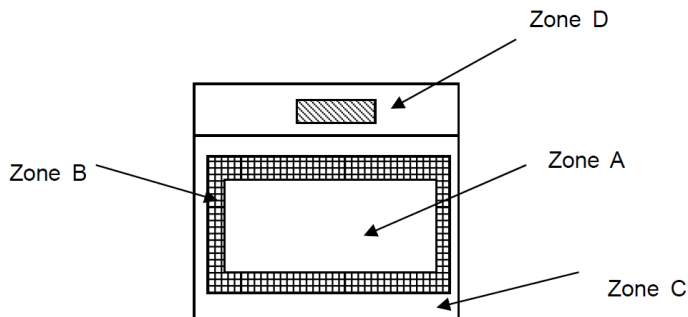

Zone A: Effective Viewing Area (Character or Digit can be seen)

Zone B: Viewing Area except Zone A

Zone C: Outside (Zone A + Zone B) Area which cannot be seen after assembly by customer.

Zone D: IC Bonding Area

Note: Generally, visual defects in Zone C can be ignored when it doesn't affect product function or appearance after assembly by customer

8.3.3 Criteria & Acceptable Quality Level

Partition	AQL
Major	0.65
Minor	1.5

LCD: Liquid Crystal Display, TP: Touch Panel, LCM: Liquid Crystal Module

No.	Items	Criteria	Classification of defects
1	Functional Defects	1) No display, Open or miss line 2) Display abnormally, Short 3) Backlight no lighting, abnormal lighting. 4) TP no function	Major
2	Missing	Missing component	
3	Outline Dimension	Overall outline dimension beyond the drawing is not allowed	
4	Color Tone	Color unevenness, refer to limited sample	Minor
5	Spot Line Defect	Light dot, Dim spot, polarizer bubble, polarizer accidented spot.	
6	Soldering Appearance	Good soldering, peeling off is not allowed.	
7	LCD/Polarizer	Black/White spot/line, scratch, crack, etc.	



Note 1:

- a) Light dot : Dots appear bright and unchanged in size in which LCD panel is displaying under black pattern.
- b) Dim dot: Dots appear dark and unchanged in size in which LCD panel is displaying under pure red, green, blue picture.

8.3.4 Criteria & Classification

Units: mm

Class	Item	Criteria																			
Minor	Spot Defect	Round type: as per following drawing, $\varnothing = (X+Y)/2$ 																			
		1) Light Dot (Black/white spot, pinhole, stain)																			
		<table border="1"> <thead> <tr> <th rowspan="2">Size\Zone</th> <th colspan="3">Acceptable Quantity</th> </tr> <tr> <th>A</th> <th>B</th> <th>C</th> </tr> </thead> <tbody> <tr> <td>$\varnothing \leq 0.15$</td> <td colspan="3">Ignore</td> </tr> <tr> <td>$0.15 < \varnothing \leq 0.25$</td> <td>3 (distance $\geq 10\text{mm}$)</td> <td colspan="2" rowspan="3">Ignore</td> </tr> <tr> <td>$0.25 < \varnothing \leq 0.40$</td> <td>2 (distance $\geq 10\text{mm}$)</td> </tr> <tr> <td>$0.4 < \varnothing$</td> <td>0</td> </tr> </tbody> </table>	Size\Zone	Acceptable Quantity			A	B	C	$\varnothing \leq 0.15$	Ignore			$0.15 < \varnothing \leq 0.25$	3 (distance $\geq 10\text{mm}$)	Ignore		$0.25 < \varnothing \leq 0.40$	2 (distance $\geq 10\text{mm}$)	$0.4 < \varnothing$	0
		Size\Zone		Acceptable Quantity																	
			A	B	C																
		$\varnothing \leq 0.15$	Ignore																		
		$0.15 < \varnothing \leq 0.25$	3 (distance $\geq 10\text{mm}$)	Ignore																	
		$0.25 < \varnothing \leq 0.40$	2 (distance $\geq 10\text{mm}$)																		
		$0.4 < \varnothing$	0																		
		2) Dim Spot (Light leakage, dent, dark spot)																			
		<table border="1"> <thead> <tr> <th rowspan="2">Size\Zone</th> <th colspan="3">Acceptable Quantity</th> </tr> <tr> <th>A</th> <th>B</th> <th>C</th> </tr> </thead> <tbody> <tr> <td>$\varnothing \leq 0.15$</td> <td colspan="3">Ignore</td> </tr> <tr> <td>$0.15 < \varnothing \leq 0.25$</td> <td>3 (distance $\geq 10\text{mm}$)</td> <td colspan="2" rowspan="3">Ignore</td> </tr> <tr> <td>$0.25 < \varnothing \leq 0.40$</td> <td>2 (distance $\geq 10\text{mm}$)</td> </tr> <tr> <td>$0.4 < \varnothing$</td> <td>0</td> </tr> </tbody> </table>	Size\Zone	Acceptable Quantity			A	B	C	$\varnothing \leq 0.15$	Ignore			$0.15 < \varnothing \leq 0.25$	3 (distance $\geq 10\text{mm}$)	Ignore		$0.25 < \varnothing \leq 0.40$	2 (distance $\geq 10\text{mm}$)	$0.4 < \varnothing$	0
		Size\Zone		Acceptable Quantity																	
			A	B	C																
		$\varnothing \leq 0.15$	Ignore																		
		$0.15 < \varnothing \leq 0.25$	3 (distance $\geq 10\text{mm}$)	Ignore																	
		$0.25 < \varnothing \leq 0.40$	2 (distance $\geq 10\text{mm}$)																		
		$0.4 < \varnothing$	0																		
		3) Polarizer Accidented Spot																			
		<table border="1"> <thead> <tr> <th rowspan="2">Size\Zone</th> <th colspan="3">Acceptable Quantity</th> </tr> <tr> <th>A</th> <th>B</th> <th>C</th> </tr> </thead> <tbody> <tr> <td>$\varnothing \leq 0.2$</td> <td colspan="3">Ignore</td> </tr> <tr> <td>$0.2 < \varnothing \leq 0.5$</td> <td>2 (distance $\geq 10\text{mm}$)</td> <td colspan="2" rowspan="2">Ignore</td> </tr> <tr> <td>$0.5 < \varnothing$</td> <td>0</td> </tr> </tbody> </table>	Size\Zone	Acceptable Quantity			A	B	C	$\varnothing \leq 0.2$	Ignore			$0.2 < \varnothing \leq 0.5$	2 (distance $\geq 10\text{mm}$)	Ignore		$0.5 < \varnothing$	0		
		Size\Zone		Acceptable Quantity																	
A	B		C																		
$\varnothing \leq 0.2$	Ignore																				
$0.2 < \varnothing \leq 0.5$	2 (distance $\geq 10\text{mm}$)	Ignore																			
$0.5 < \varnothing$	0																				
4) Polarizer Bubble																					
<table border="1"> <thead> <tr> <th rowspan="2">Size\Zone</th> <th colspan="3">Acceptable Quantity</th> </tr> <tr> <th>A</th> <th>B</th> <th>C</th> </tr> </thead> <tbody> <tr> <td>$\varnothing \leq 0.2$</td> <td colspan="3">Ignore</td> </tr> <tr> <td>$0.2 < \varnothing \leq 0.4$</td> <td>3 (distance $\geq 10\text{mm}$)</td> <td colspan="2" rowspan="2">Ignore</td> </tr> <tr> <td>$0.4 < \varnothing$</td> <td>0</td> </tr> </tbody> </table>	Size\Zone	Acceptable Quantity			A	B	C	$\varnothing \leq 0.2$	Ignore			$0.2 < \varnothing \leq 0.4$	3 (distance $\geq 10\text{mm}$)	Ignore		$0.4 < \varnothing$	0				
Size\Zone		Acceptable Quantity																			
	A	B	C																		
$\varnothing \leq 0.2$	Ignore																				
$0.2 < \varnothing \leq 0.4$	3 (distance $\geq 10\text{mm}$)	Ignore																			
$0.4 < \varnothing$	0																				

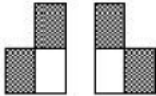
Class	Item	Criteria		
		5) Pixel Bad Points		
		Item	Zone A	Acceptable Quantity
		Bright dot	Random	$N \leq 2$
			2 dots adjacent	$N \leq 0$
			3 dots adjacent	$N \leq 0$
		Dark dot	Random	$N \leq 2$
			2 dots adjacent	$N \leq 0$
			3 dots adjacent	$N \leq 0$
		Distance	1. Minimum Distance Between Bright dots. 2. Minimum Distance Between dark dots 3. Minimum Distance Between dark and bright dot.	5mm
		Total bright and dark dot		$N \leq 4$
		<p>Note:</p> <p>A) Bright dot : Dots appear bright and unchanged in size in which LCD panel is displaying under black pattern.</p> <p>B) Dark dot: Dots appear dark and unchanged in size in which LCD panel is displaying under pure red, green, blue picture.</p> <p>C) 2 dot adjacent = 1 pair = 2 dots</p> <p>Picture:</p> <div style="display: flex; justify-content: space-around; align-items: flex-start;"> <div style="text-align: center;">  <p>2 dot adjacent</p> </div> <div style="text-align: center;">  <p>2 dot adjacent</p> </div> </div> <div style="display: flex; justify-content: space-around; align-items: flex-start; margin-top: 20px;"> <div style="text-align: center;">  <p>2 dot adjacent (vertical)</p> </div> <div style="text-align: center;">  <p>2 dot adjacent (slant)</p> </div> </div>		

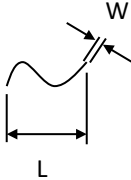
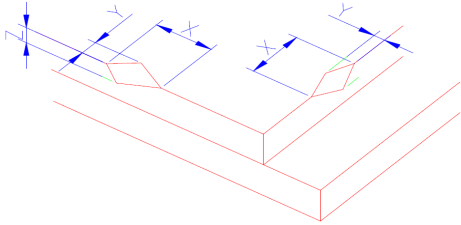
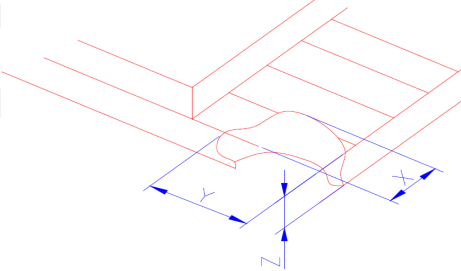
Class	Item	Criteria																											
Minor	Line Defect (LCD/TP/ Polarizer backlight black/white line, scratch, stain)	Line type: as per following drawing 																											
		<table border="1"> <thead> <tr> <th rowspan="2">Width</th> <th rowspan="2">Length</th> <th colspan="3">Acceptable quantity</th> </tr> <tr> <th>A</th> <th>B</th> <th>C</th> </tr> </thead> <tbody> <tr> <td>$W \leq 0.05$</td> <td>Ignore</td> <td colspan="3">Ignore</td> </tr> <tr> <td>$0.05 < W \leq 0.06$</td> <td>$L \leq 4.0$</td> <td colspan="2">N ≤ 3</td> <td rowspan="2">Ignore</td> </tr> <tr> <td>$0.06 < W \leq 0.08$</td> <td>$L \leq 3.0$</td> <td colspan="2">N ≤ 2</td> </tr> <tr> <td>$0.08 < W$</td> <td colspan="4">Define as spot defect</td> </tr> </tbody> </table>	Width	Length	Acceptable quantity			A	B	C	$W \leq 0.05$	Ignore	Ignore			$0.05 < W \leq 0.06$	$L \leq 4.0$	N ≤ 3		Ignore	$0.06 < W \leq 0.08$	$L \leq 3.0$	N ≤ 2		$0.08 < W$	Define as spot defect			
		Width			Length	Acceptable quantity																							
			A	B		C																							
		$W \leq 0.05$	Ignore	Ignore																									
		$0.05 < W \leq 0.06$	$L \leq 4.0$	N ≤ 3		Ignore																							
$0.06 < W \leq 0.08$	$L \leq 3.0$	N ≤ 2																											
$0.08 < W$	Define as spot defect																												
<p>Symbols: X: Length, Y: Width, Z: Height, L: Length of ITO, T: Height of LCD</p> <p>1) The edge of LCD broken: $X \leq 3.0\text{mm}$; $Y < \text{Inner border line of the seal}$; $Z \leq T$</p> 																													
<p>2) LCD corner broken: $X \leq 3.0\text{mm}$; $Y \leq L$; $Z \leq T$</p> 																													
Minor	LCD Crack/Broken																												

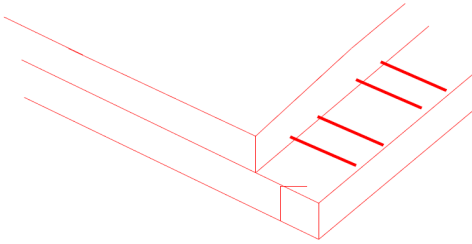
Class	Item	Criteria
Major	LCD Crack	<p>The LCD with extensive crack is not acceptable.</p> 
Major	Electronic Components SMT	Not allow missing parts, solderless connection, cold solder joint, mismatch, The positive and negative polarity opposite
Minor	Display colour & Brightness	<p>1) Colour: Measuring the colour coordinates in accordance with the datasheet or samples.</p> <p>2) Brightness: Measuring the brightness of white screen in accordance with the datasheet or samples.</p>
Minor	LCD Mura/Waving/ Hot spot	Not visible through 5% ND filter in 50% gray or judge by limit sample if necessary.

Class	Item	Criteria																											
Minor	CTP Related	1) CTP Cover Sensor Accidented Black/White Spot																											
		<table border="1"> <thead> <tr> <th rowspan="2">Size\Zone</th> <th colspan="3">Acceptable Qty</th> </tr> <tr> <th>A</th> <th>B</th> <th>C</th> </tr> </thead> <tbody> <tr> <td>$\varnothing \leq 0.1$</td> <td colspan="3">Ignore</td> </tr> <tr> <td>$0.1 < \varnothing \leq 0.2$</td> <td colspan="3">3 (distance $\geq 10\text{mm}$)</td> </tr> <tr> <td>$0.20 < \varnothing \leq 0.25$</td> <td colspan="3">2 (distance $\geq 10\text{mm}$)</td> </tr> <tr> <td>$0.25 < \varnothing$</td> <td colspan="3">0</td> </tr> </tbody> </table>	Size\Zone	Acceptable Qty			A	B	C	$\varnothing \leq 0.1$	Ignore			$0.1 < \varnothing \leq 0.2$	3 (distance $\geq 10\text{mm}$)			$0.20 < \varnothing \leq 0.25$	2 (distance $\geq 10\text{mm}$)			$0.25 < \varnothing$	0						
		Size\Zone		Acceptable Qty																									
			A	B	C																								
		$\varnothing \leq 0.1$	Ignore																										
		$0.1 < \varnothing \leq 0.2$	3 (distance $\geq 10\text{mm}$)																										
		$0.20 < \varnothing \leq 0.25$	2 (distance $\geq 10\text{mm}$)																										
		$0.25 < \varnothing$	0																										
		2) CTP Cover Scratch																											
		<table border="1"> <thead> <tr> <th rowspan="2">Width</th> <th rowspan="2">Length</th> <th colspan="3">Acceptable Qty</th> </tr> <tr> <th>A</th> <th>B</th> <th>C</th> </tr> </thead> <tbody> <tr> <td>$W \leq 0.05$</td> <td>Ignore</td> <td colspan="3">Ignore</td> </tr> <tr> <td>$0.05 < W \leq 0.06$</td> <td>$L \leq 4.0$</td> <td colspan="3">$N \leq 3$</td> </tr> <tr> <td>$0.06 < W \leq 0.08$</td> <td>$L \leq 3.0$</td> <td colspan="3">$N \leq 2$</td> </tr> <tr> <td>$0.08 < W$</td> <td colspan="3">Define as spot defect</td> </tr> </tbody> </table>	Width	Length	Acceptable Qty			A	B	C	$W \leq 0.05$	Ignore	Ignore			$0.05 < W \leq 0.06$	$L \leq 4.0$	$N \leq 3$			$0.06 < W \leq 0.08$	$L \leq 3.0$	$N \leq 2$			$0.08 < W$	Define as spot defect		
		Width			Length	Acceptable Qty																							
			A	B		C																							
$W \leq 0.05$	Ignore	Ignore																											
$0.05 < W \leq 0.06$	$L \leq 4.0$	$N \leq 3$																											
$0.06 < W \leq 0.08$	$L \leq 3.0$	$N \leq 2$																											
$0.08 < W$	Define as spot defect																												

Class	Item	Criteria	
		3) CTP Cover Pinhole / Lack of ink	
		Size\Zone	Acceptable Qty
			C
		$\varnothing \leq 0.1$	Ignore
		$0.10 < \varnothing \leq 0.25$	3 (distance $\geq 10\text{mm}$)
		$0.25 < \varnothing \leq 0.30$	2 (distance $\geq 10\text{mm}$)
		$0.30 < \varnothing$	0
		4) CTP Bonding Bubble / Accidented Spot	
		Size\Zone	Acceptable Qty
			A B
		$\varnothing \leq 0.1$	Ignore
		$0.1 < \varnothing \leq 0.2$	3 (distance $\geq 10\text{mm}$)
		$0.20 < \varnothing \leq 0.25$	2 (distance $\geq 10\text{mm}$)
		$0.25 < \varnothing$	0
Assembly Deflection: beyond the edge of backlight $\leq 0.2\text{mm}$			
Minor	CTP Related	TP cover broken X: length, Y: width, Z: height $X \leq 0.5\text{mm}$; $Y \leq 0.5\text{mm}$; $Z < \text{Cover thickness}$ *Circuitry broken is not allowed.	
			
		CTP cover broken X: length, Y: width, Z: height $X \leq 0.3\text{mm}$; $Y \leq 0.3\text{mm}$; $Z < \text{cover thickness}$ *Circuitry broken is not allowed.	
			

Criteria (functional items)

No.	Item	Criteria
1	No display	Not allowed
2	Missing segment	
3	Short	
4	Backlight no lighting	
5	CTP no function	

8.4 Dealing with Customer Complaints

8.4.1 Non-conforming Analysis

Purchaser should supply Densitron with detailed data of non-conforming sample.

After accepting it, Densitron should complete the analysis in two weeks from receiving the sample.

If the analysis cannot be completed on time, Densitron must inform the purchaser.

8.4.2 Handling of Non-conforming Displays

If any non-conforming displays are found during customer acceptance inspection which Densitron is clearly responsible for, return them to Densitron.

Both Densitron and customer should analyse the reason and discuss the handling of non-conforming displays when the reason is not clear.

Equally, both sides should discuss and come to agreement for issues pertaining to modification of Densitron quality assurance standard.

9. Reliability Specification

9.1 Reliability Tests

Test Item	Test Condition	Evaluation and Assessment
High Temperature Operation	70°C, 96 hrs	Inspection after 2~4hours storage at room temperature, the sample shall be free from defects: 1.Air bubble in the LCD; 2.Non-display; 3.Missing segments/line; 4.Glass crack; 5.Current IDD is twice higher than initial value.
Low Temperature Operation	-20°C, 96 hrs	
High Temperature Storage	80°C, 96 hrs	
Low Temperature Storage	-30°C, 96 hrs	
High Temperature & High Humidity Storage	+60°C, 90%RH, 96HR	
Thermal Shock (Non-operation)	-30°C ,30 min ↔ 80°C ,30 min, Change time:5min 20CYC.	
ESD test	C=150pF, R=330,5points/panel Air:±8KV, 5times; Contact:±6KV, 5 times; (Environment: 15°C~35°C, 30%~60%).	
Vibration (Non-operation)	Frequency range:10~55Hz, Stroke:1.5mm Sweep:10Hz~55Hz~10Hz 2 hours for each direction of X.Y.Z. (6 hours for total) (Package condition).	
Box Drop Test	1 Corner 3 Edges 6 faces,80cm (MEDIUM BOX)	

Note 1: The test samples should be applied to only one test item.

Note 2: Sample size for each test item is 5~10pcs.

Note 3: For Damp Proof Test, Pure water(Resistance > 10MΩ) should be used.

Note 4: In case of malfunction defect caused by ESD damage, if it would be recovered to normal state after resetting, it would be judged as a good part.

Note 5: Failure Judgment Criterion: Basic Specification, Electrical Characteristic, Mechanical Characteristic, Optical Characteristic.

Note 6: The color fading mura of polarizing filter should not care.

9.1.1 Inspection Check Standard

After the completion of the described reliability test, the samples are to be left at room temperature for 4 hrs prior to conducting the inspection check at 25±5 °C, 65±10% RH.

10. Handling Precautions

10.1 Handling Precautions

- 1) Since the display panel is being made of glass, do not apply mechanical impacts such as dropping from a high position.
- 2) If the display panel is broken by some accident and the internal organic substance leaks out, be careful not to inhale nor lick the organic substance.
- 3) If the liquid crystal touches your skin or clothes, wash it off immediately using soap and plenty of water
- 4) If pressure is applied to the display surface or its neighbourhood of the display module, the cell structure may be damaged and be careful not to apply pressure to these sections.
- 5) The polarizer covering the surface of the display module is soft and easily scratched. Please be careful when handling the display module.
- 6) When the surface of the polarizer of the display module has soil, clean the surface. It takes advantage of by using following adhesion tape.
 - a. Scotch Mending Tape No. 810 or an equivalent
 - b. Never try to breathe upon the soiled surface nor wipe the surface using cloth containing solvent such as ethyl alcohol, since the surface of the polarizer will become cloudy.
 - c. Also, pay attention that the following liquid and solvent may spoil the polarizer:
 - Water
 - Ketone
 - Aromatic Solvents
- 7) Hold the display module very carefully when placing it into the system housing. Do not apply excessive stress or pressure to display module. And, do not over bend the film with electrode pattern layouts. These stresses will

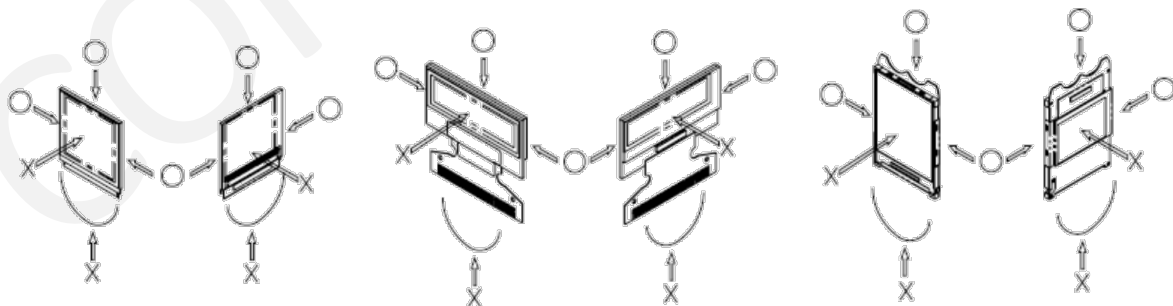

influence the display performance. Also, secure sufficient rigidity for the outer cases.

- 8) Do not apply stress to the LSI chips and the surrounding molded sections.
- 9) Do not disassemble nor modify the display module.
- 10) Do not apply input signals while the logic power is off.
- 11) Pay sufficient attention to the working environments when handing display modules to prevent occurrence of element breakage accidents by static electricity.

- a. Be sure to make human body grounding when handling display modules.
 - b. Be sure to ground tools to use or assembly such as soldering irons.
 - c. To suppress generation of static electricity, avoid carrying out assembly work under dry environments.
 - d. Protective film is being applied to the surface of the display panel of the display module. Be careful since static electricity may be generated when exfoliating the protective film.
- 12) Protection film is being applied to the surface of the display panel and removes the protection film before assembling it. If the display module has been stored for a long period of time, residue adhesive material of the protection film may remain on the surface of the display panel after removed of the film. In such case, remove the residue material by the method introduced in the above Section 5).
- 13) If electric current is applied when the display module is being dewed or when it is placed under high humidity environments, the electrodes may be corroded and be careful to avoid the above.

10.2 Storage Precautions

- 1) When storing display modules, put them in static electricity preventive bags avoiding exposure to direct sun light nor to lights of fluorescent lamps, etc. and, also, avoiding high temperature and high humidity environments or low temperature (less than 0°C) environments. (We recommend you to store these modules in the packaged state when they were shipped from Densitron) At that time, be careful not to let water drops adhere to the packages or bags nor let dewing occur with them.
- 2) If electric current is applied when water drops are adhering to the surface of the display module, when the display module is being dewed or when it is placed under high humidity environments, the electrodes may be corroded and be careful about the above.

10.3 Designing Precautions

- 1) The absolute maximum ratings are the ratings which cannot be exceeded for display module, and if these values are exceeded, panel damage may be happen.
- 2) To prevent occurrence of malfunctioning by noise, pay attention to satisfy the VIL and VIH specifications and, at the same time, to make the signal line cable as short as possible.
- 3) We recommend you to install excess current preventive unit (fuses, etc.) to the power circuit (VDD). (Recommend value: 0.5A)
- 4) Pay sufficient attention to avoid occurrence of mutual noise interference with the neighbouring devices.
- 5) As for EMI, take necessary measures on the equipment side basically.
- 6) When fastening the display module, fasten the external plastic housing section.
- 7) If power supply to the display module is forcibly shut down by such errors as taking out the main battery while the display panel is in operation, we cannot guarantee the quality of this display module.

10.4 Operation Precautions

- 1) It is indispensable to drive the display within the specified voltage limit since excessive voltage shortens its life.
- 2) Direct current causes an electrochemical reaction with remarkable deterioration of the display quality. Give careful consideration to prevent direct current during ON/OFF timing and during operation.
- 3) Response time is extremely delayed at temperatures lower than the operating temperature range while, at high temperatures, displays become dark. However, this phenomenon is reversible and does not mean a malfunction or a display that has been permanently damaged.
- 4) To protect display modules from performance drops by static electricity rapture, etc., do not touch the following sections whenever possible while handling the display modules.
 - a. Pins and electrodes
 - b. Pattern layouts such as the FPC
- 5) When the driver is being exposed (COG), semiconductor elements change their characteristics when light is radiated according to the principle of the solar battery. Consequently, if the driver is exposed to light, malfunctioning may occur.
 - a. Design the product and installation method so that the driver may be shielded from light in actual usage.
 - b. Design the product and installation method so that the driver may be shielded from light during the inspection processes.
- 6) Although the display module stores the operation state data by the commands and the indication data, when excessive external noise, etc. enters into the module, the internal status may be changed. It therefore is necessary to take appropriate measures to suppress noise generation or to protect from influences of noise on the system design.
- 7) We recommend you to construct its software to make periodical refreshment of the operation statuses (re-setting of the commands and re-transference of the display data) to cope with catastrophic noise.

10.5 Other Precautions

- 1) Request the qualified companies to handle industrial wastes when disposing of the display modules. Or, when burning them, be sure to observe the environmental and hygienic laws and regulations.